

A Link-Based Cluster Ensemble Approach For Improved Gene Expression Data Analysis

P.Balaji, Dr. A.P.Siva Kumar

Abstract: It is difficult from possibilities to select a most suitable effective way of clustering algorithm and its dataset, for a defined set of gene expression data, because we have a huge number of ways and huge number of gene expressions. At present many researchers are preferring to use hierarchical clustering in different forms, this is no more totally optimal. Cluster ensemble research can solve this type of problem by automatically merging multiple data partitions from a wide range of different clusterings of any dimensions to improve both the quality and robustness of the clustering result. But we have many existing ensemble approaches using an association matrix to condense sample-cluster and co-occurrence statistics, and relations within the ensemble are encapsulated only at raw level, while the existing among clusters are totally discriminated. Finding these missing associations can greatly expand the capability of those ensemble methodologies for microarray data clustering. We propose general K-means cluster ensemble approach for the clustering of general categorical data into required number of partitions.

Index Terms: Clustering, Categorical data, Gene data, DNA, Ensemble Approach.

1 INTRODUCTION

The usage of clustering is crucial both for extracting and visualizing useful information from the micro-array data.

1.1 Different Algorithms

We use different algorithms (or even a same algorithm with different framework) which often provide us distinct clusterings. As the result, it is purely difficult for normal users to decide which type of algorithm and framework will be *optimal* for the given set of data this is because no single- simple/ pass clustering algorithm can achieve the best for all datasets (A.L.N. Fred and A.K. Jain 2005), and mining all types of cluster structures and shapes presented in data is impossible for any existing clustering algorithm (T. Boongoen, Q. Shen, and C. Price, 2010).

1.2 K-means clustering for gene analysis

Clinical researchers extremely use simple clustering methods, such as *k*-means and agglomerative hierarchical (P.J. Rousseeuw and L. Kaufman, 1990) to cluster cancer microarray samples, in spite of the arrival of such several new techniques those capitalize on inherent characteristics of a gene expression data (high dimensionality and noise) to improve clustering quality (e.g. D. Cristofor and D. Simovici, 2002; A. Strehl and J. Ghosh, 2002; S. Guha, R. Rastogi, and K. Shim, 2000) says that, this is because the use of those methods is difficult for non-expert users.

1.2 Recent Development

In recent days, *consensus clusterings* or *cluster ensembles* have emerged as effective, simple, one-stop methods for improving the quality and robustness of the clustering results. Those Cluster ensembles combine the multiple clustering principles (referred to as 'ensemble members' or 'base clusterings') where the base clusterings contain diversity in their picking of clusters by: (i) employing multiple clustering algorithms (D. Gibson, J. Kleinberg, and P. Raghavan, 2000); (ii) using a single clustering algorithm with random parameter initializations (M.J. Zaki and M. Peters, 2005, D. Liben-Nowell and J. Kleinberg, 2007); (iii) using different subsets of gene (A.K. Jain and R.C. Dubes, 1998, T. Boongoen, Q. Shen, and C. Price, 2010); (iv) selecting a random number of clusters (Fred and Jain, 2005; C. Domeniconi and M. Al-Razgan, 2009); or (v) using data sampling techniques. The Most existing methods will compare cluster associations between each of the *N* samples in the dataset to produce an $N \times N$ pairwise similarity matrix [i.e. *consensus* (C. Domeniconi and M. Al-Razgan, 2009), *agreement* and *co-association* (Fred and Jain, 2005) matrices], to which a consensus function (e.g. agglomerative hierarchical clustering) is applied to acquire the final data partition. Which will produce the data clusters as in the k-means algorithm.

-
- P.Balaji, Dr. A.P.Siva Kumar
 - Department Of Computer Science & Engineering
 - Jawaharlal Nehru Technological University
Anantapur
 - College Of Engineering (Autonomous)

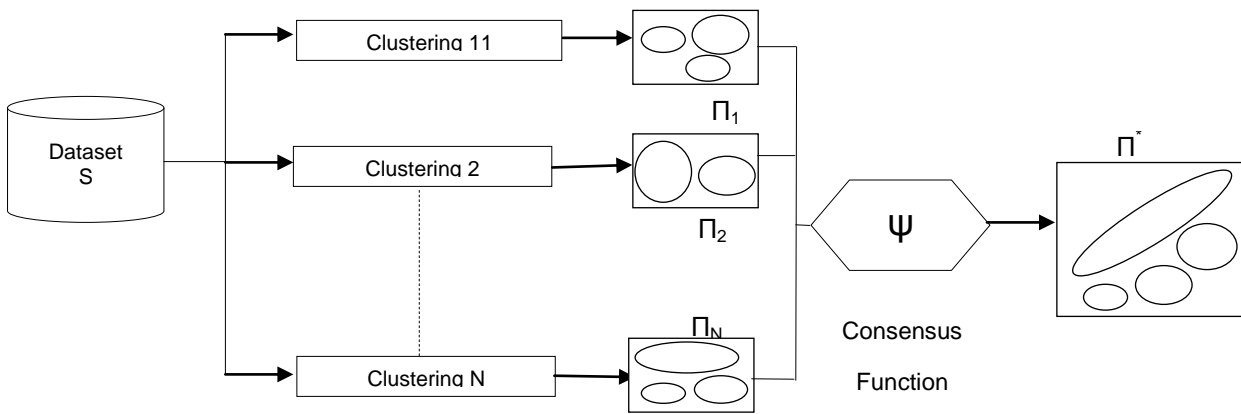

Figure 1: Ensemble Approach

With the ensemble of the two base clusterings $\Pi = \{\pi_1, \pi_2\}$ and the five samples ($x_1 \dots x_5$) those are given in figure 1, we produce the end clusters.

1.4 Modified Approach

An alternative approach (Brodley and Fern, 2004; Ghosh and Strehl, 2002) to the pairwise similarity methods which makes use of $N \times P$ binary cluster-association matrix (BM) (in which P denotes the total number of clusters in the ensemble). Figure 1 depicts an example of such procedure that has been generated from those ensembles of the data. Despite reported efficiency and success, these methods generate the optimal clustering results based on the incomplete information of the cluster ensemble. The underlying association matrix gives sample-cluster relations between them at a row level and totally ignores the relations among clusters. As the result, performance of such approaches may subsequently be degraded as many as matrix entries are left *unknown*, each referred with zero. In response to it, we prefer a new method—the LCE—for the clustering of data. It significantly extends that of the hybrid bipartite graph formulation technique (HBGF) (Brodley and Fern, 2004), by applying the graph-based consensus function to the improved cluster association matrix, instead of conventional BM. This article extends its application to the problem of clustering cancer microarray samples, and will beshown to refine cluster-association matrix, as well as minimizing the number of such unknown entries and, hence, we can increase accuracy; moreover for it, it can easily augment or replace a researcher's existing clustering tools. And also we can reduce the clustering time so that we can get quick results as compared to normal approach.

2. MODEL OF MODIFIED K-MEANS CLUSTERING FOR GENE ANALYSIS

The proposing LCE methodology can be illustrated in Figure 2. This includes three major steps in process: (i) creating M base groupings or clusters to form a cluster ensemble;

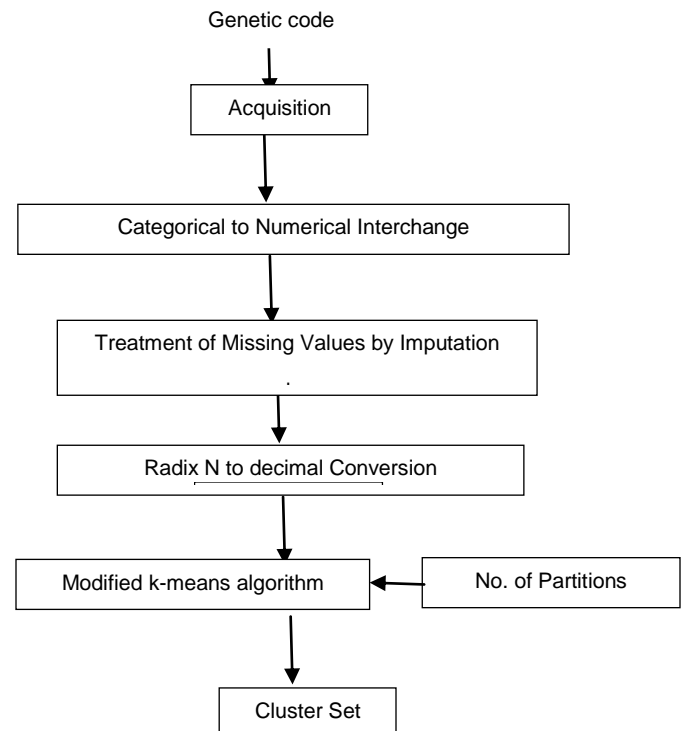

Figure 2: gene cluster model

(ii) Creating the refined cluster-association matrix (RM) by using the link-based similarity algorithm procedure (Weighted Connected-Triplets, WCT); and (iii) by generating the destined data partition by utilizing the modified k-means clustering partitioning technique as the consensus function. This framework is similar to HBGF technique (Fern and Brodley, 2004), and except the second step which is introduced for developing a refined information matrix.

2.1 Gene data Acquisition

The single 'gene' is the most similar that to a single 'word' in English language. Nucleotides (molecules) those make up the genes can be seen as 'letters' in English language. The single gene can have a small numbers of nucleotides or the large number of nucleotides, in same way that the word can be large or small (e.g. 'electrophysiology' vs 'cell'). The single gene often interacts with the neighboring genes to

produce the cellular function and can even be ineffectual without the neighboring genes. It can be seen in same way that the 'word' can have meaning only in the context of a 'sentence.' The series of the nucleotides can be put together without forming the gene, like a string of letters can be put together without forming the word in the code. Eg:ujkgipm

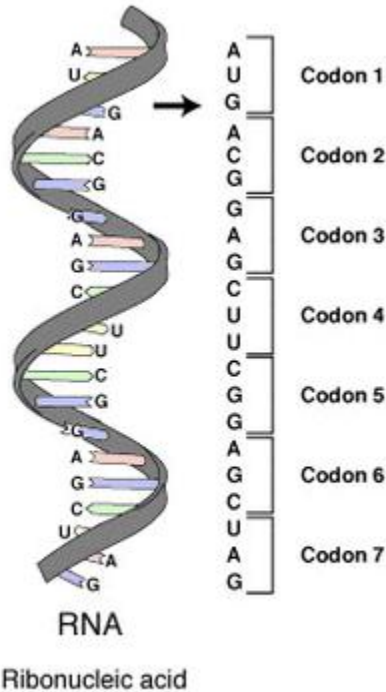

Figure 3: Genetic Structure in DNA

2.2 Categorical to numerical exchange

Gene data consists of n*3 table like structure and while representing it row represents nucleotides and column for

each gene. As there are only n nucleotides replace every nucleotide to respective numbers by using the replacement techniques. We can represent the model frame work as $\prod_{\{A,C,I,T\}} = \{C_1^1, C_1^2, C_1^3, \dots, C_1^{N_1}\} \iff \prod_{\{1,2,3,4\}} = \{C_2^1, C_2^2, C_2^3, \dots, C_2^{N_2}\}$

GENE	CODON 1	CODON 2	CODON 3
I	A	C	I
II	I	T	A
III	A	C	T
IV	I	I	T

GENE	CODON 1	CODON 2	CODON 3
I	1	2	3
II	3	4	1
III	1	2	4
IV	3	3	4

Figure 4: State change

2.3 Treatment of Missing Values (Imputation)

At some places in the datasets there may occur missing values which will decrease the quality of the data partitioning. So we go for data treatment by calculating the means for individual columns and replacing the data with the mean. Hence we can bring some more quality into the algorithm.

$$X_{(n)} = \{\sum_{i=1 \text{ to } n} (X_{i,n})\}/n$$

$$S\{X_1, X_2, \emptyset, \dots, \emptyset, \dots, X_N\} \leftrightarrow S^1\{X_1, X_2, X_n, \dots, X_n, \dots, X_N\}$$

Here we use Expectation-Maximization algorithm for replacing the imputed values or we can say that the data set will be put to preprocess before we apply the clustering algorithm. Hence first we will apply the Expectation-Maximization algorithm to the dataset before the original clustering algorithm to get more accuracy.

		Second Position									
		U		C		A		G			
		code	Amino Acid	code	Amino Acid	code	Amino Acid	code	Amino Acid		
First Position	U	UUU	phe	UCU	ser	UAU	tyr	UGU	cys	U	Third Position
		UUC		UCC		UAC		UGC		C	
		UUA	leu	UCA		UAA	stop	UGA	stop	A	
		UUG		UCG		UAG	stop	UGG	trp	G	
	C	CUU	leu	CCU	pro	CAU	his	CGU	arg	U	
		CUC		CCC		CAC		CGC		C	
		CUA		CCA		CAA	CGA	A			
		CUG		CCG		CAG	CGG	G			
	A	AUU	lie	ACU	thr	AAU	asn	AGU	ser	U	
		AUC		ACC		AAC		AGC		C	
		AUA		ACA		AAA	AGA	A			
		AUG		ACG		AAG	AGG	G			
	G	GUU	val	GCU	ala	GAU	asp	GGU	gly	U	
		GUC		GCC		GAC		GGC		C	
		GUA		GCA		GAA	GGA	A			
		GUG		GCG		GAG	GGG	G			

Figure 5: Nucleotide nomenclature

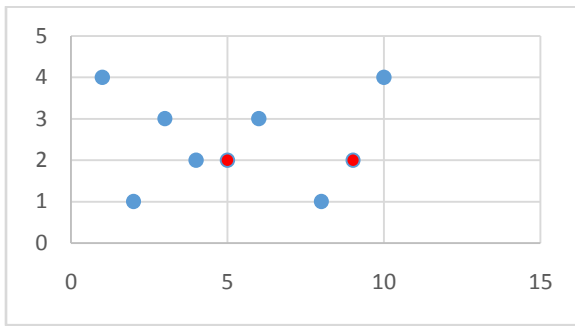

Fig 6: Replacing missing values with mean

2.4 Radix N-Conversion

As we have the values only up to the total number of codons in the gene data, We have to convert it into Base 10 variable set. Let $S\{X_1, X_2, X_n, \dots, X_n, \dots, X_N\}$ be a variable gene data where X_i be a particular gene of n codons then it will be having up to values n from 1. It will emerge with 2 cases.

Case 1: If $n=10$

There need not need of conversion

Case 2: If $n \neq 10$

Convert the total dataset into base 10.

1. Let n be the number of digits in the number. For example, 104 has 3 digits, so $n=3$.
2. Let b be the base of the number. For example, 104 is decimal so $b = 10$.
3. Let s be a running total, initially 0.
4. For each digit in the number, working left to right do: Subtract 1 from n . multiply the digit times b^n and add it to s .
5. When your done with all the digits in the number, its decimal value will be s

$$S\{X_1, X_2, X_3, \dots, X_N\} \longrightarrow S_1\{Y_1, Y_2, Y_3, \dots, Y_N\}$$

2.5 K-means algorithm

The k-means algorithm is the most globally used clustering algorithm and it can be applied to many fields in science and technology. But one of the problems of this k-means algorithm is it may produce null clusters depending on the initial center vectors. For static dataset execution of k-means algorithm, this is considered as insignificant and also can be solved by the execution of the algorithm for many number of times. In those situations, where k-means can be used as the integral part of higher level applications, this null cluster problem can produce anomalous behavior of that system and it may lead to the significant performance degradation. Hence we propose modified K-means Algorithm.

3. MODIFIED K-MEANS ALGORITHM

The execution steps of the m_k -means algorithm to form clusters are essentially similar to those of the original k-means algorithm. The processor maintains the cluster structures in its own local memory and iterates through the steps of the m_k -means algorithm to evaluate a final set of cluster centers Z . The execution steps to be followed are summarized below.

Input: a set D of d -dimensional data and an integer K .

Output: K clusters

Algorithm:

begin randomly pick K points $\in D$ to be initial means; **while** measure M is not stable **do**

begin

compute distance $d_{ij} = \|x_i - z_k\|$ for each

k, j where $1 \leq j \leq K$ and $1 \leq i \leq N$, and

determine members of new K subsets based upon minimum distance to z_k for $1 \leq j \leq K$;

compute new center z_k for $1 \leq j \leq K$ using k-means;

compute C

end

end

$$J(K, m) = \sum_{k=1}^K \sum_{i=1}^N (u_{ki})^m d^2(x_i, c_k)$$

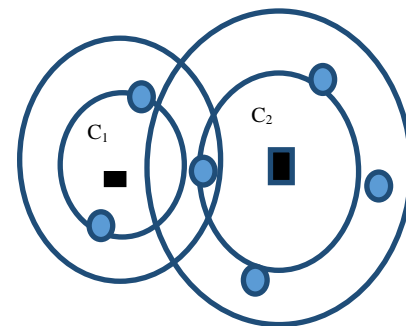

Figure 7: Modified K-means cluster

Clustering in gene expression data sets is a challenging problem. Different algorithms for clustering of genes have been proposed. However due to the large number of genes only a few algorithms can be applied for the clustering of samples. k-means algorithm and its different variations are among those algorithms. But these algorithms in general can converge only to local minima and these local minima are significantly different from global solutions as the number of clusters increases.

4. RESULTS

Experimental Work: Experimental work was designed to compare the performance of proposed K-mean algorithm. Number of data elements selected was 1000. And for the sake of experiment, 8 numbers of clusters (k) were entered at run time. The process was repeated 10 times for different data sets generated by MATLAB. The

proposed K-mean algorithm is efficient because of less number of iterations and improved cluster quality, as well as reduced elapsed time. In Figure 2, Basic and proposed K-mean clustering algorithms are compared in terms of different data sets. For each run different data sets are generated by MATLAB and entered, to observe the number of iterations. In Figure 3, Basic and proposed K-mean clustering algorithms are compared in terms of same data set. For each run same data set is entered, to observe that at each time numbers of iterations are different in basic K-mean clustering algorithm. The numbers of iterations are fixed in proposed K-mean clustering algorithm because initial centroids are not selected randomly. Basic K-mean clustering algorithm gives different clusters, as well as clusters size differs in different runs. Table 1 shows different results for same data set as well as elapsed time

	normal k-means	Modified k-means
1	31	24
2	32	24
3	29	17
4	34	20
5	34	19
6	28	25
7	28	25
8	29	25
9	30	27
10	59	49

Table 1: For different data set

We can represent the above table in graphical interface bar chart as in figure 7.

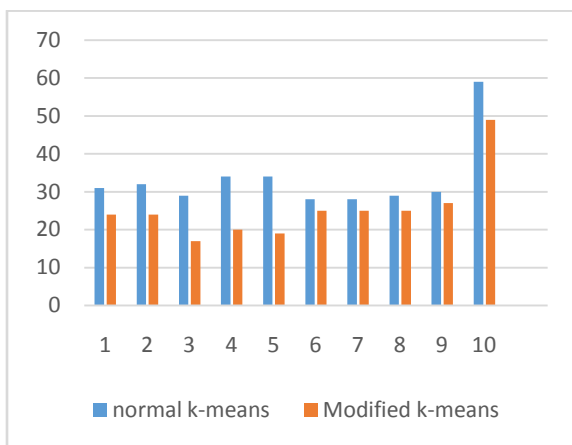

Fig. 8: For different data set

Proposed K-mean clustering algorithm gives same clusters, as well as clusters size is same in different runs. Table 2 shows same number of iterations and cluster size. In this as the size of data becomes high the value of the iterations becomes much higher and the time complexity will be high. Hence by considering it for the genetic data as the total number of genes will be in the order of merely thousands we can go through the modified k-means approach which

will produce the more efficient results in less number of iterations. As the same mean will be there for cluster there won't be change in any of the iteration to other.

Gene	normal k-means	Modified k-means
1	31	24
2	32	24
3	29	17
4	34	20
5	34	19
6	28	25
7	28	25
8	29	25
9	30	27
10	59	49

Table 2: For Same Dataset

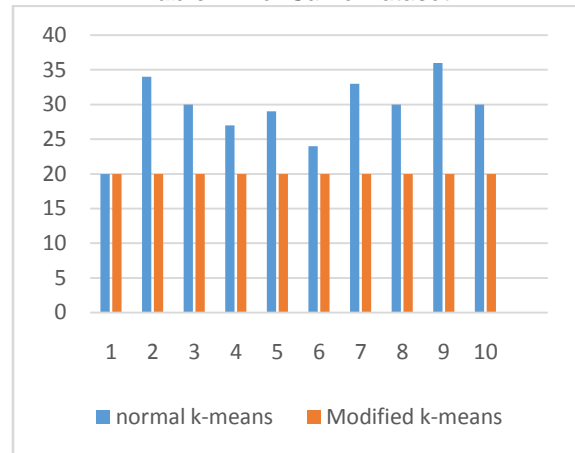

Fig. 9: For same data set

As a result, many categorical data clustering algorithms have been introduced in recent years, with applications to interesting domains such as protein interaction data. The initial method was developed in by making use of Gower's similarity coefficient. Following that, the k-modes algorithm in extended the Conventional k-means with a simple matching dissimilarity measure and a frequency-based method to update centroids (i.e., clusters' representative). For the more values in the case of gene data the normal k-means and modified k-means algorithm will show the following results in the case of yeast gene and mitochondria. Here we can neatly observe that the number of iterations will be reduced as compared to that of normal k-means algorithm to modified k-means algorithm. Hence even though it have more executing steps due to this the execution time becomes low in the case of the modified approach.

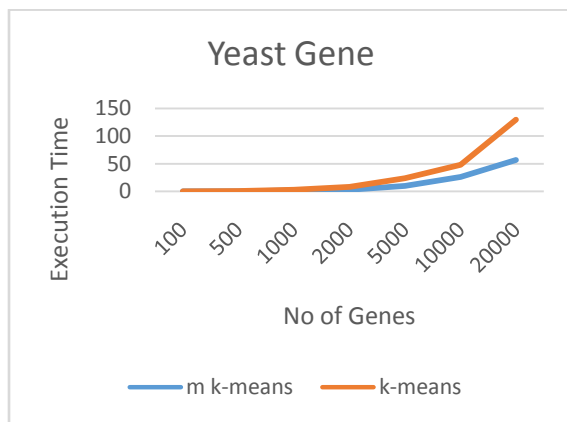

Figure 10: Representation of Graph between Execution Time and Genes in Yeast Gene

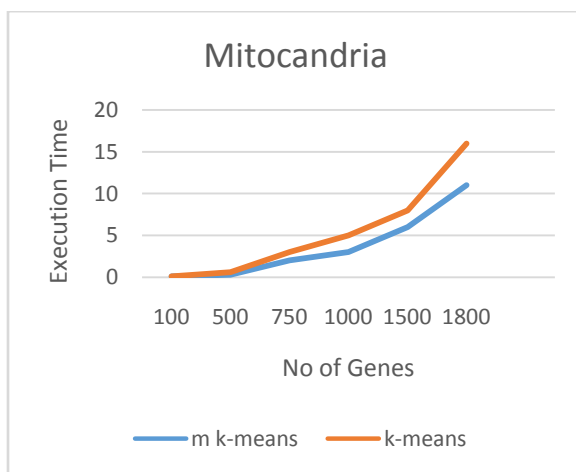

Figure 10: Representation of Graph between Execution Time and Genes in Yeast Gene

Conclusion:

This paper presents a novel, highly effective link-based cluster ensemble approach to categorical data clustering. The empirical study, with different ensemble types, validity measures, and data sets, suggests that the proposed link-based method usually achieves superior clustering results compared to those of the traditional categorical data algorithms and benchmark cluster ensemble techniques. The prominent future work includes an extensive study regarding the behavior of other link-based similarity measures within this problem context. Also, the new method will be applied to specific domains, including tourism and medical data set.

References:

- [1] P.J. Rousseeuw and L. Kaufman, Finding Groups in Data: Introduction to Cluster Analysis. Wiley Publishers, 1990.
- [2] J. Kittler, M. Hatef, R. Duin, and J. Matas, "On Combining Classifiers," IEEE Trans. Pattern Analysis and Machine Intelligence, vol. 20, no. 3, pp. 226-239, Mar. 1998.
- [3] J.C. Gower, "A General Coefficient of Similarity and Some of Its Properties," Biometrics, vol. 27, pp. 857-871, 1971.
- [4] D. Cristofor and D. Simovici, "Finding Median Partitions Using Information-Theoretical-Based Genetic Algorithms," J. Universal Computer Science, vol. 8, no. 2, pp. 153-172, 2002.
- [5] A. Strehl and J. Ghosh, "Cluster Ensembles: A Knowledge Reuse Framework for Combining Multiple Partitions," J. Machine Learning Research, vol. 3, pp. 583-617, 2002.
- [6] S. Guha, R. Rastogi, and K. Shim, "ROCK: A Robust Clustering Algorithm for Categorical Attributes," Information Systems, vol. 25, no. 5, pp. 345-366, 2000.
- [7] G. Karypis and V. Kumar, "Multilevel K-Way Partitioning Scheme for Irregular Graphs," J. Parallel Distributed Computing, vol. 48, no. 1, pp. 96-129, 1998.
- [8] C. Domeniconi and M. Al-Razgan, "Weighted Cluster Ensembles: Methods and Analysis," ACM Trans. Knowledge Discovery from Data, vol. 2, no. 4, pp. 1-40, 2009.
- [9] X.Z. Fern and C.E. Brodley, "Solving Cluster Ensemble Problems by Bipartite Graph Partitioning," Proc. Int'l Conf. Machine Learning (ICML), pp. 36-43, 2004.
- [10] D. Gibson, J. Kleinberg, and P. Raghavan, "Clustering Categorical Data: An Approach Based on Dynamical Systems," VLDB J., vol. 8, nos. 3-4, pp. 222-236, 2000.
- [11] A.L.N. Fred and A.K. Jain, "Combining Multiple Clusterings Using Evidence Accumulation," IEEE Trans. Pattern Analysis and Machine Intelligence, vol. 27, no. 6, pp. 835-850, June 2005.
- [12] M.J. Zaki and M. Peters, "Clicks: Mining Subspace Clusters in Categorical Data via Kpartite Maximal Cliques," Proc. Int'l Conf. Data Eng. (ICDE), pp. 355-356, 2005.
- [13] D. Liben-Nowell and J. Kleinberg, "The Link-Prediction Problem for Social Networks," J. Am. Soc. for Information Science and Technology, vol. 58, no. 7, pp. 1019-1031, 2007.
- [14] A.K. Jain and R.C. Dubes, Algorithms for Clustering. Prentice-Hall, 1998.
- [15] T. Boongoen, Q. Shen, and C. Price, "Disclosing False Identity through Hybrid Link Analysis," artificial Intelligence and Law, vol. 18, no. 1, pp. 77-102, 2010.