

The Educational And Technical Development For ARM-Based Camera

Yi-Jen Mon, Zhi-Jia Gu, Jia-Rong Wu

Abstract: The education of embedded system for students is popular in many institutes or universities recently. In this paper, the Advanced RISC Machine 9 (ARM9) based software called android developer suite (ADS) is combined with DMA 2440 educational kit to let students practice theoretical and experimental knowledge of embedded systems. The ADS will be illustrated at first then an example of camera application is demonstrated. The good experimental results and students' learning assessments are revealed in this paper.

Index Terms: Android, ARM, Camera, android developer suite (ADS), Embedded system's education.

1 INTRODUCTION

The Android operation system (OS) based products have been developed rapidly in many areas. The Android OS is mainly used in embedded systems such as mobile phone, camera, monitoring systems and vehicle electrical products, etc. Based on this demands, the curriculums of embedded systems are opened in many departments of information engineering of institutes or universities. Android based devices are already smarter than before. Their good features can be found in many embedded products or portable devices [1]. The data collection processes of Android devices are developed by exploring special device boot modes and Android's partitioning schema [2]. Android can support many collaborations of access of teams of mobile users by enabling anytime and anywhere such as to share every contact data [3-5]. Many researches of Android or Advanced RISC Machine (ARM) are demonstrated, for example, the research of face recognition technology based on ARM9 and Android based Linux operating system can be found in [6]. The method of designing the CMOS camera driver based on ARM CPU of S3C2440 has been developed in [7]. In this paper, the ARM9 based Samsung S3C2440A CPU [8], Android developer suite (ADS) [9] and educational development kit named as DMA 2440 manufactured by DMATEK Ltd, Taiwan [10] are used to do experimental courses of camera control. The experimental results reveal that the good performances and students' learning assessments are possessed. In simulation, the inverted pendulum system is illustrated to demonstrate the performance of this proposed scheme. The simulation results are revealed that the good robustness and performance are possessed.

2 THE ARM DEVELOPER SUITE (ADS)

Android Application is developed by software development kits (SDK) issued by android web [1]. It includes many kits such as JDK(Java Development Kit), Eclipse, ADT(Android Development Tools), Android SDK, etc. For the ARM developer suite (ADS), it is an integrated development environment (IDE) supported to us to compile a debugging build target and an optimized build target of code targeted at hardware based on an ARM CPU and Android OS. The ADS is based on Metrowerks CodeWarrior IDE version 4.2. It has been tailored to support the ADS toolchain. It provides [9]:

- ARM-specific configuration panels that enable us to configure the ARM development tools from within the CodeWarrior IDE.
- ARM-targeted project stationery that enables us to create basic ARM and Thumb projects from the CodeWarrior IDE.
- Although most of the ARM toolchain is tightly integrated with the CodeWarrior IDE, there are a number of areas of functionality that are not implemented by the ARM version of the CodeWarrior IDE. In most cases, these are related to debugging, because the ARM debuggers are provided separately. The diagram of ADS project window is shown in Fig. 1. The Editor window for C program of this paper is shown in Fig. 2. The Compile window for C program of this paper is shown in Fig. 3.

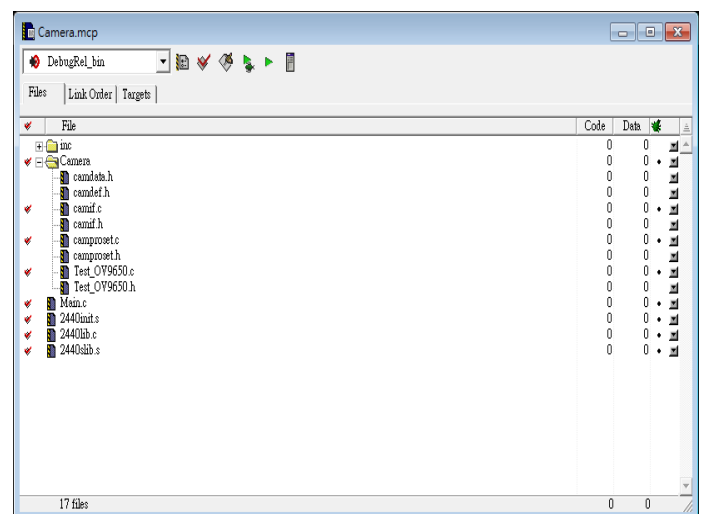

Fig. 1. The diagram of ADS project window

- Yi-Jen Mon et al., Department of Computer Science and Information Engineering, Taoyuan Innovation Institute of Technology, Chung-Li, Taoyuan, Taiwan, R. O. C. monbuy@tiit.edu.tw

```

void Camera_Iic_Test(void)
{
    int i, camclk;

    CameraModuleSetting();

    Uart_Printf("\n**** IIC Master Tx/Rx Test Program with %s Camera Module ****\n", CAM_NAME);

    while(1) {
        i=0;
        Uart_Printf("\n\n");

        while(1) { //display menu
            Uart_Printf("%2d:%s\n", i, func_cammodule_test[i][1]);
            i++;
            if((int)(func_cammodule_test[i][0])==0) {
                Uart_Printf("\n");
                break;
            }
            if(i%4==0)
                Uart_Printf("\n");
        }

        Uart_Printf("\nPress Enter key to exit : ");
        i = Uart_GetIntNum();

        if(i==1) break; // return.
        if(i>=0 && (i<((sizeof(func_cammodule_test)-1)/8))) // select and execute...
            ((void (*)(void)) (func_cammodule_test[i][0]))();
    }

    Uart_Printf("\n");
    rINTMSK |= BIT_IIC;
}
    
```

Fig. 2. The Editor window for C program

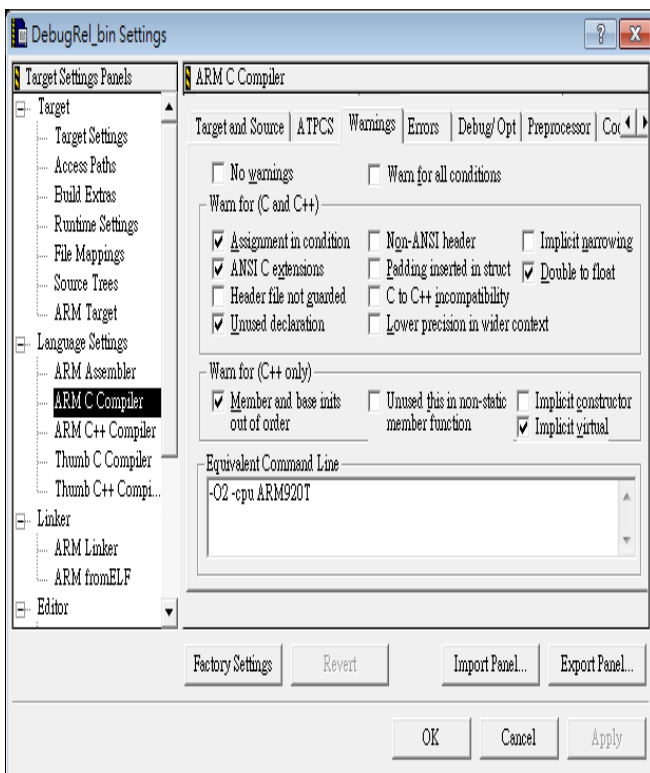

Fig. 3. The Compile window for C program

3 EXPERIMENTAL RESULTS

SAMSUNG S3C2440 uses 16/32 bit ARM920T RISC technology for the core. Its main Frequency is 400M Hz. The S3C2440A is developed with ARM920T core, 0.13um CMOS standard cells and a memory complier. Its low power consumption, simple, elegant and fully static design is particularly suitable for cost and power sensitive applications. It adopts a new bus architecture known as Advanced Micro controller Bus Architecture (AMBA). The S3C2440A offers outstanding features with its CPU core, a 16/32-bit ARM920T RISC processor designed by Advanced RISC Machines (ARM), Ltd. The ARM920T implements MMU, AMBA BUS, and Harvard cache architecture with separate 16KB instruction and 16KB data caches, each with an 8-word line length. Block diagram of ARM is shown in Fig. 4 [9]. It provides a camera interface to support camera applications. The schematic diagram is shown in Fig. 5 [10]. In this paper, the image capture is used to test and teach students to learn basic theoretical and implemental applications of camera. One of the results is shown in Fig. 6, it can capture real image shown in touch screen. This curriculum of embedded system is welcomed by students. They are all satisfied with this course. In assessments of every students in class of 30 students, the number of students feel strongly satisfied is 27, the number of students feel satisfied 2, not satisfied just 1 student.. From this topic of course of embedded system, good experimental results and students' learning assessments are revealed in this paper.

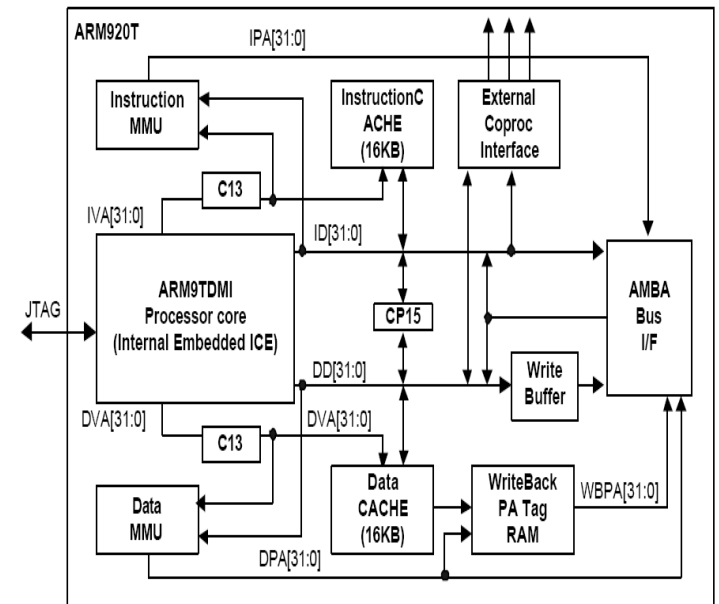

Fig. 4. The block diagram of ARM 2440 CPU [9]

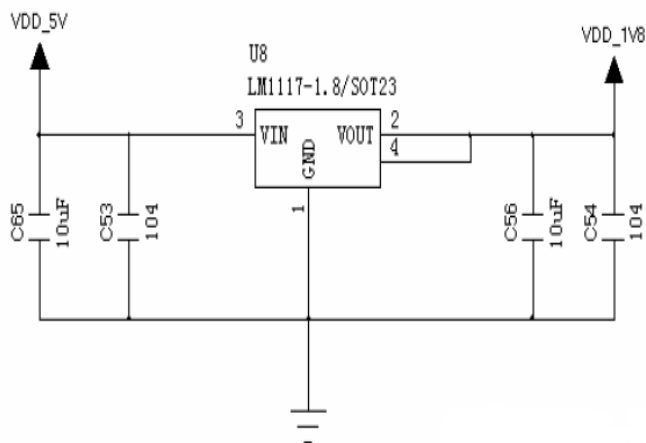

Fig. 5. The schematic diagram of Camera of DMA 2440 kit [10]

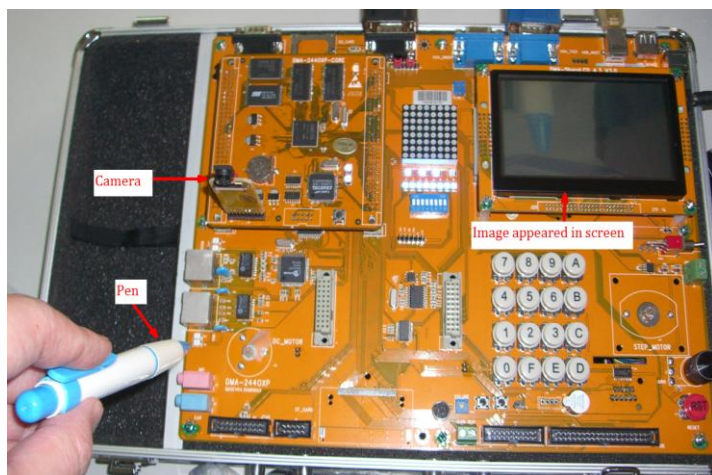

Fig.6. Photograph of the implemental result for image captured by camera

4 CONCLUSION

In this paper, the Android and ARM developer suite (ADS) have been installed successfully to develop image captured by camera applications. This is verified by the ARM9 based DMA 2440 kit. The development of image captured applications can be used to develop other different peripheral applications. The experimental results are also revealed that good performances and students' assessments are possessed.

ACKNOWLEDGMENT

The author wants to give thanks to the Editor and Reviewers for their valuable comments and partially funded by teacher's research project of Taoyuan Innovation Institute of Technology, Taiwan, R. O. C.

REFERENCES

- [1]. Android user guide, <http://www.android.com>
- [2]. T. Vidas, C. Zhang and N. Christin, Toward a general collection methodology for Android devices, *Digital Investigation*, Vol. 8, 2011, Pages S14-S24.
- [3]. V. S. Pascual and F. Xhafa, Evaluation of contact synchronization algorithms for the Android platform, *Mathematical and Computer Modelling*, 2012, doi:10.1016/j.mcm.2011.12.039.

- [4]. B. Yang, Y. Zhan and S. Ma, "Hardware Design of High-Speed Data Acquisition System Based on ARM9," *Advances in Computer, Communication, Control and Automation: Lecture Notes in Electrical Engineering*, vol. 121, pp 101-108, 2012.
- [5]. V. Srikanth and G. Leelavathi, "Video Monitoring System Based on ARM9," *International Journal of Innovative Technology and Exploring Engineering*, vol. 1, no. 3, pp. 16-19, 2012
- [6]. J. N. Elipe, M. Patil, S. Tejaswi and R. P. Nraiah, "Implementation of embedded face recognition system based on Linux and ARM9," *World Journal of Science and Technology*, vol. 2, no. 10, pp. 79-82, 2012.
- [7]. J. Sun and S. Wang, "Research and Implementation of the CMOS Camera Device Driver Based on S3C2440," *2010 International Conference on Intelligent Computation Technology and Automation (ICICTA)*, vol. 2, pp. 1039-1042, 2010.
- [8]. Samsung 2440 CPU data sheet, <http://www.samsung.com>.
- [9]. ARM Ltd. User guide, <http://www.arm.com>
- [10]. DMA 2440 user guide, <http://www.dmatek.com.tw>.