

# Design Of Single-Axis And Dual-Axis Solar Tracking Systems Protected Against High Wind Speeds

Mai Salaheldin Elsherbiny, Dr. Wagdy R. Anis, Dr. Ismail M. Hafez, Dr. AdelR. Mikhail

**Abstract:** Solar energy is rapidly gaining ground as an important mean of expanding renewable energy use. Solar tracking is employed in order to maximize collected solar radiation by a photovoltaic panel. In this paper we present a prototype for Automatic solar tracker that is designed using Arduino UNO with Wind sensor to Cease Wind effect on panels if wind speed exceeds certain threshold. The Proposed solar tracker tracks the location of the sun anywhere in any time by calculating the position of the sun. For producing the maximum amount of solar energy, a solar panel must always be perpendicular to the source of light. Because the sun motion plane varies daily and during the day it moves from east to west; one needs two axis tracking to follow the sun's position. Maximum possible power is collected when two axis tracking is done. However, two axis tracking is relatively costly and complex. A compromise between maximum power collection and system simplicity is obtained by single axis tracking where the plane (North south axis) is fixed while the east west motion is accomplished. This work deals with the design of both single and two axis tracking systems. Automatic trackers is also compared to Fixed one in terms of Energy generated, Efficiency, Cost and System reliability.

**Index Terms:** Photovoltaic, Solar energy, Single axis tracking, Dual axis tracking, Maximum power, Arduino UNO.

## 1 INTRODUCTION

Energy crisis is one of the most important issues in today's world. Conventional energy resources are limited and are one of the primary reason for environmental pollution. The use of renewable energy is becoming increasingly popular[1].As far as we know solar technologies are emerging very rapidly all over the world because of their eco-friendly current generation and various applications they have. A solar tracker is one of the famous devices used that orients a payload toward the sun. In photovoltaic applications, trackers are used to minimize the angle of incidence between the incoming sunlight and a photovoltaic panel to maximize the amount of energy produced from PV system.

### 1.1 Simulation model

In this section, it will be explained the Solar angles used in designing the system so as to calculate the sun position at any time, at any location on any day of year.

#### 1.1.1 Solar Declination( $\delta$ )

The angle that the Sun's rays make with the equatorial plane is known as the declination angle (Figure 1). This angle is the solar declination. On any day,  $\delta$  is taken as a constant which changes on the next day. Cooper's empirical relation for calculating the solar declination angle (in degrees)

$$\text{Where } \delta = 23.45 \sin\left[\left(284 + d\right) \times \frac{360}{365}\right] (1)$$

Where that:  $d = \text{day of the year } (1 \leq d \leq 365)$

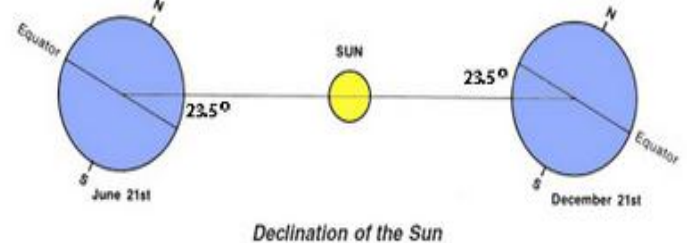

Fig1. Solar declination angle.

Solar declination can also be defined as the angle between the line joining the centers of the Sun and the Earth and its projection on the equatorial plane. The solar declination changes mainly due to the rotation of Earth about an axis. Its maximum value is  $23.45^\circ$  on 21 December and the minimum is  $-23.45^\circ$  on 21 June[2].

#### 1.1.2 Latitude( $\phi$ ) and Longitude (Lt)

Latitude  $\phi$  gives the location of a place on Earth, i.e. north or south of the equator. Latitude is an angular measurement ranging from  $0^\circ$  at the equator to  $90^\circ$  at the poles ( $90^\circ\text{N}$  or  $90^\circ\text{S}$ ) for the north and south poles, Shown in figure 2.

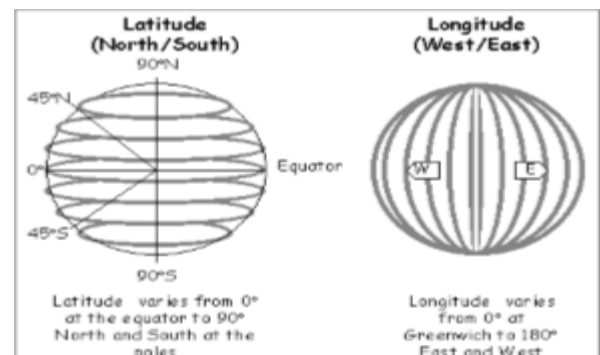

Fig2. Latitude ( $\phi$ ) and Longitude (Lt).

- Wagdy R Anis Professor, department of Electronics and Communication Engineering, Faculty of Engineering Ain Shams University, Cairo, Egypt. E-mail: [wagdyanis51@yahoo.com](mailto:wagdyanis51@yahoo.com)
- Ismail M. Hafez Professor, department of Electronics and Communication Engineering, Faculty of Engineering Ain Shams University, Cairo, Egypt. E-mail: [ismail\\_hafez@eng.asu.edu.eg](mailto:ismail_hafez@eng.asu.edu.eg)
- Adel R. Mikhail Assistant Professor, National Telecommunication institute, Cairo, Egypt. E-mail: [Adelrefkyq@yahoo.com](mailto:Adelrefkyq@yahoo.com)

On the Earth, a meridian ( $L_t$ ) is an imaginary north–south line between the North Pole and the South Pole that connects all locations with a given longitude. The position on the meridian is given by the latitude, each being perpendicular to all circles of latitude at the intersection points. The meridian that passes through Greenwich (England) is considered as the prime meridian, all the places on that meridian have the same longitude. The Earth can be divided in two parts with reference to the prime meridian, viz. eastern and western hemispheres. The maximum distant meridian on both sides can be at  $0^\circ$  to  $180^\circ$  from the principal meridian[2].

### 1.1.3 Hour Angle ( $\omega$ )

The hour angle is the measure of the angular displacement of the Sun through which the Earth has to rotate to bring the meridian of the place directly under the Sun. At sunrise, the value of  $\omega$  will be maximum, then it will slowly and steadily reduce and keep reducing with time until solar noon. At this point  $\omega$  becomes zero. It starts increasing the moment after solar noon and will be maximum at sunset. The values at sunrise and sunset are numerically the same but have opposite signs. Which gives the time elapsed since the celestial body's last transit at the observer's meridian for a positive hour angle or the time expected for the next transit for a negative hour angle (1 hour =  $15^\circ$ ) [2], Figure shown in figure 3.

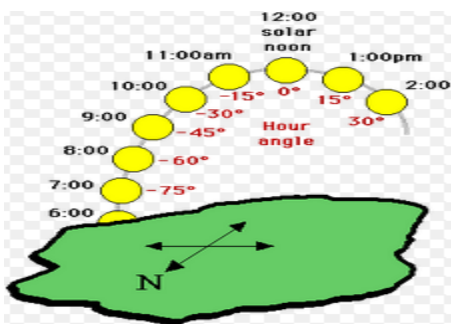

Fig3. Hour angle.

### 1.1.4 Tilt angle ( $\beta$ )

This is the angle between the plane of the solar collector and the horizontal. If a panel is lying flat, then it is  $0^\circ$ . As you tip it up, this angle increases. It does not matter which direction the panel faces. but in our case panel should face the equator to obtain maximum energy.

## 1.2 Photovoltaic Systems

They supply electric power using the sun, their efficiency is directly related to the amount of solar energy acquired by the system. The more solar energy acquired, the more electric power supplied. So it is necessary to follow the sun to increase the efficiency. There are Different Types of Photovoltaic Systems such as :

### 1.2.1 Fixed Photovoltaic system

Fixed Photovoltaic system is adjusted at certain Tilt angle ( $\beta$ ). It is the simplest and least expensive type. It will be completely stationary hence, throughout the day, the collected power decreases significantly, and it almost collect all of its energy at noon time where the panel is

perpendicular at Solar rays of the Sun. The panel is directed towards the equator (directed towards south in northern hemi-sphere). The Tilt angle ( $\beta$ ) is adjusted to be about the latitude angle ( $\phi$ ) so that maximum energy is collected throughout the year.

### 1.2.2 Automatic photovoltaic Tracking system

Automatic Photovoltaic system is designed using trackers which has two types:

#### a) Single axis tracker

Single axis trackers have one degree of freedom that acts as an axis of rotation. The axis of rotation of single axis trackers is typically aligned along a true north meridian. It is possible to align them in any cardinal direction with advanced tracking algorithms. A single axis tracker tracks the sun east to west. There are several common implementations of single axis trackers. These include HSAT (horizontal single axis trackers), VSAT (vertical single axis trackers), TSAT (tilted single axis trackers) and PSAT (polar aligned single axis trackers). The orientation of the module with respect to the tracker axis is important when modeling performance[3]. Figure 4 shows single axis tracker.

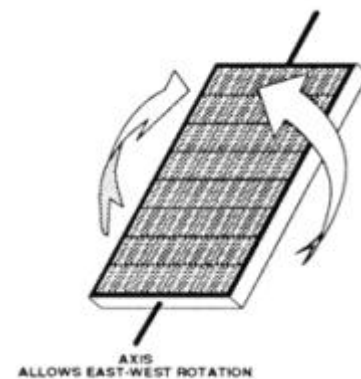
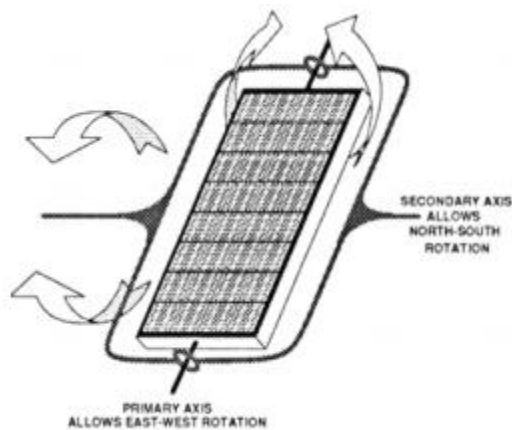

Fig4. Single axis tracker

#### b) Dual axis tracker

Dual axis trackers have two degrees of freedom that act as axes of rotation. These axes are typically normal to one another. The axis that is fixed with respect to the ground can be considered a primary axis. The axis that is referenced to the primary axis can be considered a secondary axis. There are several common implementations of dual axis trackers. They are classified by the orientation of their primary axes with respect to the ground. two-axis tracker tracks the daily east to west movement of the sun and the daily declination movement of the sun. Two common implementations are TTDAT (tip-tilt dual axis trackers) and AADAT (azimuth-altitude dual axis trackers)[3]. Figure 5 shows Dual axis tracker.



**Fig5.** Dual axis tracker

Some Dual axis trackers are designed by using Light Detecting sensors (LDRs), it consists of two sets of phototransistor sensors, two motors and PIC controller. One set of sensors and one motor is used to tilt the tracker in sun's east - west direction and the other set of sensors and the other motor which is fixed at the bottom of the tracker is used to tilt the tracker in the sun's north-south direction. The light sensor's consists of two LDR's placed on either side of the panel separated by an opaque plate. Depending on the intensity of the sun rays one of the two LDR's will be shadowed and the other will be illuminated. The LDR present in the side, in which the intensity of the sun rays is higher, will generate a stronger signal and the other will generate a weaker signal. The difference in the output voltage between the two LDR's will help in the movement of the PV panel in the direction in which the intensity of the sun rays is maximum[4]. but they are not working that exact due to their limitations like Shadow factor, cause if there is Clouds the two sensors will not be illuminated so the panel will not track and also will lose track if the Clouds disappear. The alternate solution proposed here is Dual axis trackers based on calculating the position of the sun using sun motion equation are more reliable cause it get over the shadowing effect by prediction of the position of the sun and moving the tracker regardless there is shadowing or not. in addition to solving the problem of Wind speed if it exceeds certain Threshold using wind sensor and stopping the system to save the panel and continue tracking if the wind level below this threshold.

### 1.3 Review on Solar Tracking PV systems

In this section, A review of a lot of previous studies done on Single and Dual axis trackers is presented such as :

#### 1.3.1 Single Axis Trackers

Agarwal and Pal [5] designed a computer based one axis solar tracking system. LDR is used as photo sensor to sense the incident solar radiation. A computer based stepper motor is used in the tracking system to provide motion to the photovoltaic panel. The results show that, in cloudy weather, the system cannot track the actual position of the actual position of the sun, because of the absence of shading effect. Al-Haddad and Hassan [6] designed a one axis solar tracking system. The control part of the system is made using electronic circuit that have the op-amp LM324

as the main component. While for the mechanical part, the moving base of the reflector of the satellite receiver antenna is used. Measurements have been made for comparison between fixed and tracking system. The results have shown that, the tracking system is effective in the sense of relatively high output power increase and low cost. Abdallah and Badran [7] designed a single axis sun-tracking system for enhancing solar still productivity. A computerized sun tracking device is used for rotating the solar still with the movement of the sun. In this study, the programming method of control works efficiently in all weather conditions regardless of the presence of clouds. The calculated values of the surface positions as a function of time are fed to the PLC program to control the actuator of the sun position tracker, 24 V AC electrical motor. A comparison between fixed and sun tracked solar stills shows that the use of sun tracking increased the productivity for around 22%, due to the increase of overall efficiency by 2%. It can be concluded that, the sun tracking is more effective than fixed system and it is capable of enhancing the productivity.

#### 1.3.2 Dual Axis Trackers

Roth, et al. [8] designed a two axis sun tracking system. The tracker gives the possibility for automatic measuring of direct solar radiation with a pyrliometer. In the active operation mode, the tracker uses the signal of a sun detecting linear sensor to control the pointing. Two stepper motors move the instrument platform, keeping the sun's beam at the center of the sensor. Duarte, et al. [9] designed a two axis sun tracking system. This work studies the solution of two axis solar tracking system based on solar maps, which can predict the exact apparent position of the sun, by the latitude's location, thereby avoiding the need to use sensors or guidance systems. To accomplish this, it is used a low-power microcontroller, suitably programmed, to control two electric motors to ensure that the panels supporting structure is always oriented towards the sun.

## 2DESIGN METHODOLOGY

### 2.1 Dual Axis Tracker based on motion algorithm with wind sensor

The proposed tracking system tracks the sunlight by rotating the PV panel in two different axes. The dual-axis solar tracker follows the angular height position of the sun in the sky in addition to following the sun's east-west movement. This solution of two axis solar tracking system based on motion algorithm, which can predict the exact apparent position of the sun, by the latitude's location, thereby avoiding the need to use sensors or guidance systems. To accomplish this, it is used a low-power microcontroller, suitably programmed, to control two electric motors to ensure that the panels supporting structure is always oriented towards the sun. The tracker model consists of Real Time Clock, Wind sensor, Arduino UNO microcontroller, Solar Panel and two stepper motors in which the Stepper motors are basically performing function of sun tracking, one of them is used to track the sun's east - west movement from Sun rise to Sunset during the day. The other one is used to adjust the Tilt angle daily. The Block diagram for dual axis tracker is shown in Figure 6.

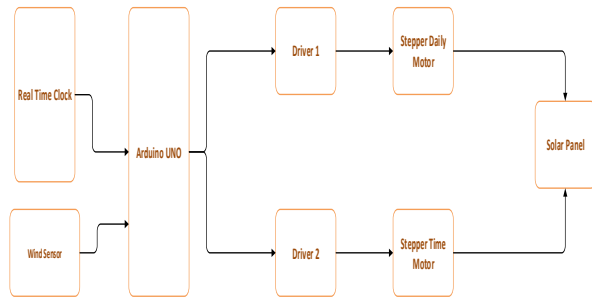

Fig6. System Block Diagram.

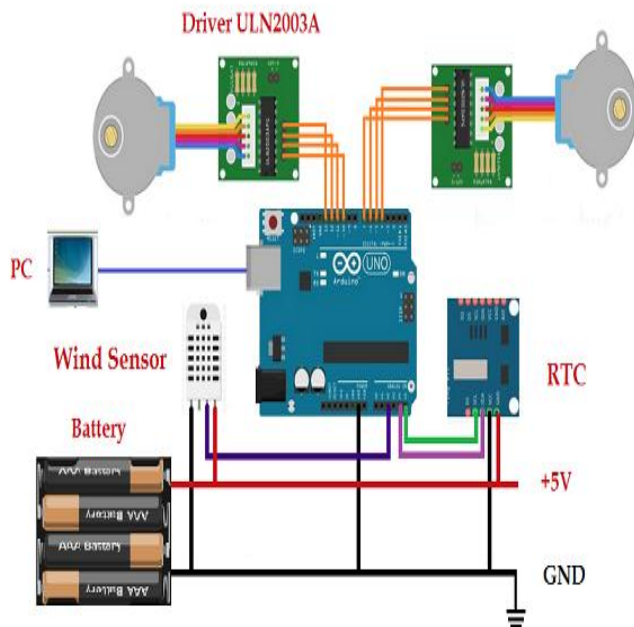

Fig7. Tracking System.

**2.2 Software/System Operation**

The program for the tracking system has been written using C language code. The software operation is as follows: First of all the program checks the day from the adjusted RTC (Real Time Clock) chip, then checks the time of the day if it equals to Sun Rise time of this day which is calculated from this equation

$$Tsr = 12 - \frac{12}{\pi} \cos^{-1}(-\tan \phi \tan \delta) [Tsr \dots \dots \text{Sun Rise Time}] \dots (3)$$

where  $\phi$ :Cairo Latitude angle which equals to 30 degrees. then the Tilt angle will be calculated according to this equation :

$$\beta = \phi - \delta, \text{ :Tilt angle} \dots (2)$$

As a result of Calculating the Tilt angle the movement of the two motors will start as below:

▪ **Day Motor**

It moves Every day once throughout the day to Adjust the Solar panel Tilt angle according to Eq.2. The adjustment is done once a day and in our case this is done just at sunrise. The System is designed to make Tilt angle equal to zero during the period between Sunset and next Sunrise to protect solar panel against wind hazards.

▪ **Time Motor (East - West motion)**

It is used to Adjust the Solar panel to Track the Sun all over the day During the interval from Sun Rise to Sun Set time and the motion of the motor will be calculated as below :

Since Hour angle ( $\omega$ ).....(1 hour =15°)

So the motor is adjusted to rotate 1.5 degrees every 6 minutes which is equivalent to fixed number of Steps for the stepper motor. The second part of the program is to check the Wind,we have two cases :

**Case1: The Wind Exceeds the Critical value**

The program checks if the Wind speed exceeds 30 km/hr,so the Tilt angle will be set to Zero and day Motor will return to its initial position to make the Solar panel in horizontal position. the program keep checking until the Wind speed is below 30km/hr,if so Tilt angle will be calculated and returns time Motor to its predicted position according to the day.

**Case2: The wind below the critical value**

The program will check the time till it reaches the Sun Set time according to this equation

$$Tss = 12 + \frac{12}{\pi} \cos^{-1}(-\tan \phi \tan \delta) [Tss \dots \dots \text{Sun Set Time}] \dots (4)$$

if so the program stops the time motor.The Tilt angle will be Zero and the day motor will return to its initial position so the solar panel will be horizontal and the Time motor will return to its original position. Then the program checks the Sun Rise Time of the next day to move the motors to their new positions. Figure8 shows the Tracker flow algorithm.



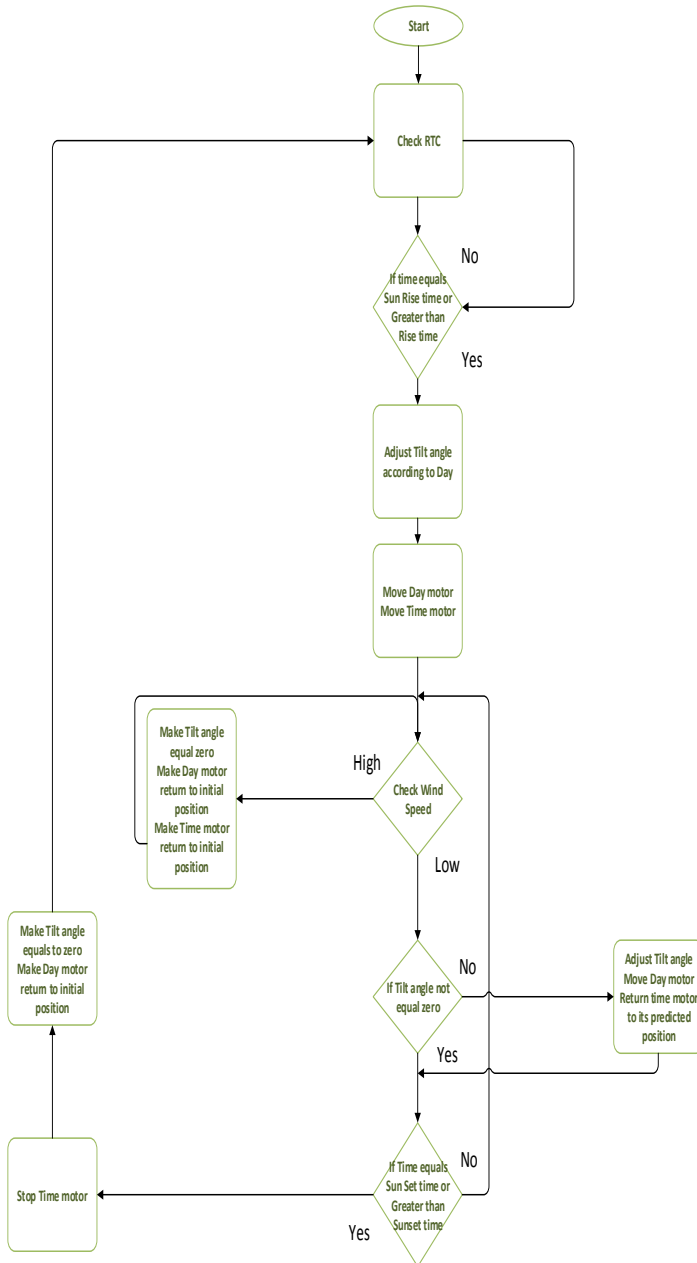

Fig8. Tracker Flow Algorithm

**2.3 Single Axis Tracker based on motion algorithm with wind sensor**

The design is made for Dual Axis tracker as the Single Axis tracker is a special case from Dual one. So the design of single axis tracker will have only one degree of freedom to track the Sun all over the day during the interval from Sun Rise to Sun Set time by rotating daily motor and Tilt angle will be fixed and is set to 30° in Cairo, Egypt.

**3. RESULTS**

Energy is calculated during the year using three techniques Fixed system, One axis system and Dual axis system. The simulation is done by setting Tilt angle  $\beta = 30^\circ$  for Fixed system and one axis Tracking. for two axis tracking  $\beta$  varies

daily according to Eq. (2). This simulation is done in Cairo, Egypt [ 10].

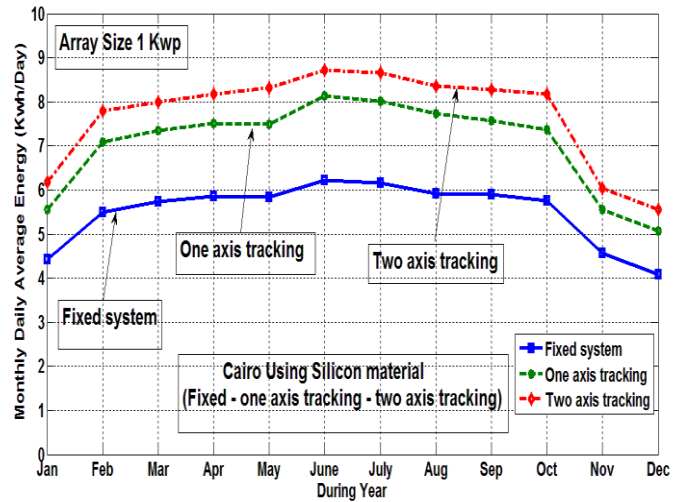

Fig9. The Comparison between Monthly daily average energy in Cairo for Silicon fixed system, one axis tracing system and two axis tracking System.[10]

In Fig. 9 shown above the curve of Monthly daily average energy produced by 1Kwp Silicon array installed in Cairo in Kwh per day for Fixed system, the energy increase from 4.428 Kwh/day on January till maximum 6.227 Kwh/day on June and decrease till minimum 4.09 Kwh/day on December, One axis tracking system the energy increase from 5.551 Kwh/day on January till maximum 8.143 Kwh/day on June and decrease till minimum 5.067 Kwh/day on December, Two axis tracking system the energy increase from 6.171 Kwh/day on January till maximum 8.723 Kwh/day on June and decrease till minimum 5.559 Kwh/day on December [6]. So we conclude that two axis tracking system produced the highest energy.

**4. CONCLUSION**

In this paper we have come to a conclusion that dual-axis solar tracker is more efficient in terms of the electrical energy output when compared to the single axis tracker and fixed system. The gain of the dual-axis tracking system is about 40% compared with the fixed system. also we can't neglect that dual axis tracker is more complex due to the tracking system used so it will be more expensive and less reliable than fixed system. The gain of the single-axis tracker systems is about 28% compared with the fixed system, so a compromise between maximum power collection and system simplicity is obtained.

**5. REFERENCES**

- [1] Sameer Meshram, Sharad Valvi and Nilesh Raykar. 2016, "A Cost-effective Microcontroller based Sensor for Dual Axis Solar Tracking", ISSN: 2172-038 X, No.14 May 2016.
- [2] Saeed Mansour, Dr. Wagdy R. Anis, Dr. Ismail M. Hafez. 2015, ISSN 2277-8616, VOLUME 4, ISSUE 05, MAY 2015.
- [3] Ceyda Aksoy Tirmikci and Cenk Yavuz. 2015,

Comparison of Solar Trackers and Application of a Sensor Less Dual Axis SolarTracker”,(2015)556-561doi10.17265/1934-8975/2015.06.006.

- [4] Deepthi.S, Ponni.A, Ranjitha.R and R Dhanabal. 2013,“Comparison of Efficiencies of Single-Axis Tracking System and Dual-Axis Tracking System with Fixed Mount”,ISSN: 2319-5967, Volume 2, Issue 2, March 2013.
- [5] Agarwal, S., and Pal, S. 2011. “Design, Development and Testing of a PC based One Axis Suntracking System for Maximum Efficiency.” *Sensors & Transducers Journal* 131 (8): 75-82.
- [6] Al-Haddad, M. K., and Hassan, S. S. 2011. “Low Cost Automatic Sun Path Tracking System.” *Journal of Engineering* 17 (1): 116-30.
- [7] Abdallah, S., and Badran, O. 2008. “Sun Tracking System for Productivity Enhancement of Solar Stil.” *Desalination* 220 (1-3): 669-76.
- [8] Roth, P., Georgiev, A., and Boudinov, H. 2005. “Cheap Two Axis Sun Following Device.” *Energy Conversion and Management* 46 (7-8): 1179-92.
- [9] Duarte, F., Gaspar, P. D., and Gonçalves, L. C. 2011. “Two Axes Solar Tracker based on Solar Maps Controlled by a Low-Power Microcontroller.” *Journal of Energy and Power Engineering* 5 (7): 671-6.
- [10] Simon Ezzat, Dr. Wagdy R. Anis, and Dr. Ismail M. Hafez. 2017, “Design of photovoltaic Grid connected using solar tracking systems”, Vol.7-No.3, pp.88-100, ISSN 2250-1797, May-June 2017.